



# Model: D2DB-750

## Data

---

Type: Semi-hermetic piston compressors

Producer: Copeland

Series: DISCUS

## Model: D2DB-750

### Technical data

Cylinder count:	2
Displacement [m <sup>3</sup> /h]:	28
Weight [kg]:	145
Oil charge [dm <sup>3</sup> ]:	2,3
Max. operating current [A]:	15,6
Locked rotor current [A]:	70
Power supply [V/~/Hz]:	380-420V/3/50Hz

### Connections

	<u>milimeters</u>	<u>inches</u>
Suction line:		1 3/8"
Discharge line:		1 1/8"

R22

**Cooling capacity [kW]**

<b>t<sub>c</sub> \ t<sub>e</sub></b>	<b>-25</b>	<b>-20</b>	<b>-15</b>	<b>-10</b>	<b>-5</b>	<b>0</b>	<b>5</b>	<b>10</b>
<b>30</b>	8.30	10.73	13.54	16.81	20.57	24.89	29.82	35.41
<b>35</b>	7.62	9.96	12.67	15.81	19.42	23.57	28.30	33.67
<b>40</b>	6.94	9.20	11.80	14.81	18.27	22.23	26.76	31.91
<b>45</b>	-	8.45	10.94	13.81	17.11	20.89	25.22	30.14
<b>50</b>	-	7.72	10.09	12.82	15.96	19.56	23.67	28.36
<b>55</b>	-	-	9.26	11.85	14.82	18.23	22.13	26.58
<b>60</b>	-	-	8.45	10.89	13.69	16.91	20.59	24.80

**Power input [kW]**

<b>t<sub>c</sub> \ t<sub>e</sub></b>	<b>-25</b>	<b>-20</b>	<b>-15</b>	<b>-10</b>	<b>-5</b>	<b>0</b>	<b>5</b>	<b>10</b>
<b>30</b>	3.53	3.86	4.16	4.40	4.57	4.64	4.61	4.46
<b>35</b>	3.69	4.09	4.44	4.75	5.00	5.16	5.23	5.19
<b>40</b>	3.85	4.29	4.71	5.09	5.41	5.66	5.82	5.88
<b>45</b>	-	4.49	4.97	5.41	5.81	6.14	6.39	6.55
<b>50</b>	-	4.68	5.21	5.72	6.18	6.59	6.94	7.19
<b>55</b>	-	-	5.45	6.01	6.55	7.04	7.46	7.81
<b>60</b>	-	-	5.67	6.30	6.90	7.46	7.97	8.41

**Current [A]**

<b>t<sub>c</sub> \ t<sub>e</sub></b>	<b>-25</b>	<b>-20</b>	<b>-15</b>	<b>-10</b>	<b>-5</b>	<b>0</b>	<b>5</b>	<b>10</b>
<b>30</b>	7.89	8.34	8.75	9.08	9.31	9.42	9.38	9.16
<b>35</b>	8.11	8.64	9.14	9.57	9.91	10.15	10.25	10.18
<b>40</b>	8.33	8.93	9.51	10.04	10.50	10.86	11.09	11.18
<b>45</b>	-	9.21	9.87	10.50	11.07	11.55	11.92	12.15
<b>50</b>	-	9.47	10.22	10.95	11.62	12.22	12.72	13.10
<b>55</b>	-	-	10.55	11.37	12.16	12.88	13.51	14.03
<b>60</b>	-	-	10.88	11.79	12.67	13.51	14.27	14.93

**Mass flow [kg/s]**

<b>t<sub>c</sub> \ t<sub>e</sub></b>	<b>-25</b>	<b>-20</b>	<b>-15</b>	<b>-10</b>	<b>-5</b>	<b>0</b>	<b>5</b>	<b>10</b>
<b>30</b>	180.47	230.46	287.28	351.91	425.30	508.43	602.24	707.72
<b>35</b>	172.45	222.48	279.24	343.69	416.81	499.55	592.87	697.74
<b>40</b>	164.16	214.17	270.81	335.04	407.82	490.12	582.90	687.12
<b>45</b>	-	205.66	262.12	326.07	398.47	480.27	572.45	675.96
<b>50</b>	-	197.06	253.30	316.91	388.86	470.12	561.64	664.39
<b>55</b>	-	-	244.46	307.68	379.14	459.79	550.60	652.54
<b>60</b>	-	-	235.72	298.50	369.41	449.40	539.45	640.52

**C.O.P. [W/W]**

$t_c \setminus t_e$	-25	-20	-15	-10	-5	0	5	10
<b>30</b>	2.36	2.78	3.26	3.82	4.51	5.36	6.46	7.93
<b>35</b>	2.06	2.44	2.85	3.33	3.89	4.56	5.41	6.49
<b>40</b>	1.80	2.14	2.50	2.91	3.38	3.93	4.60	5.43
<b>45</b>	-	1.88	2.20	2.55	2.95	3.40	3.95	4.60
<b>50</b>	-	1.65	1.94	2.24	2.58	2.97	3.41	3.94
<b>55</b>	-	-	1.70	1.97	2.26	2.59	2.97	3.40
<b>60</b>	-	-	1.49	1.73	1.98	2.27	2.58	2.95

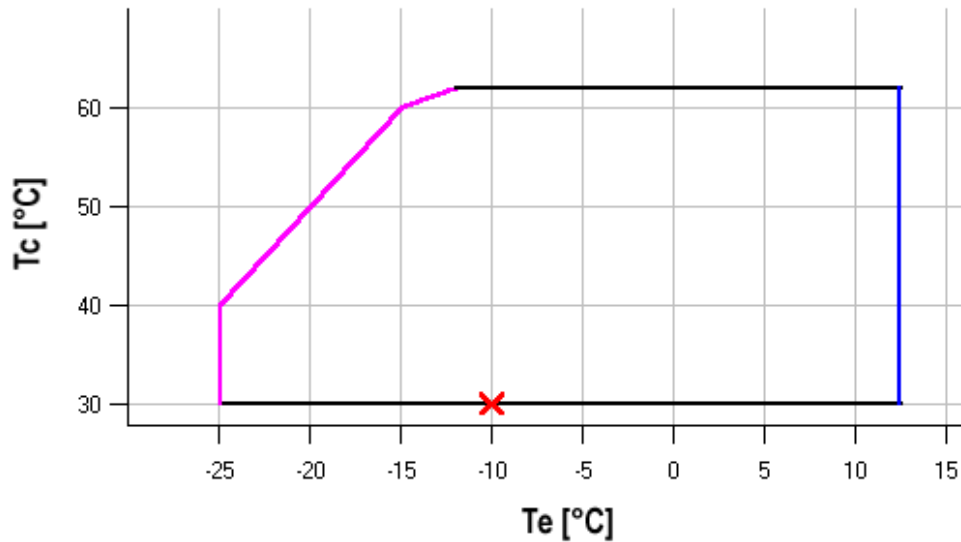
**Application range**

- Maximum evaporating temperature
- 25°C suction gas return

Operating conditions: ISO; subcooling: 0 K, suction superheat: 10 K, return gas temperature: -  
 $t_c$  - Condensing temperature [°C]  
 $t_e$  - Evaporating temperature [°C]

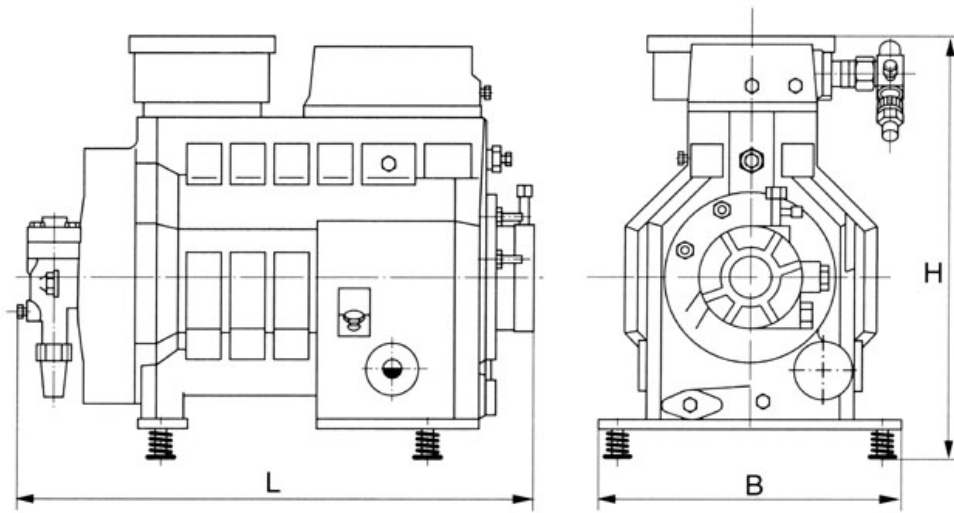

L	590 mm
B	330 mm
H	470 mm

